Installation Instructions and Technical Documentation

GSM-Messenger

Remote Monitoring System for

- Level indicators (1 - 4 indicators)
 - Alarm/Error contact monitoring
 - Consumption and event counter
 - Operating hours counter function
-



<u>Content</u>	<u>Page:</u>
BASIC FUNCTIONS	2
COUNTING FUNCTIONS	2
SIM CARD	2
OILVIEW CONNECTION	2
ELECTRICAL INSTALLATION	4
DISPLAYING LEDS	6
DEVICE REPORTS	7
DEVICE PARAMETERIZATION	7
SMS REPORTS	7
TECHNICAL DATA	8
OPTIONS AND ACCESSORY	8
LABELING	8

GSM-Messenger

Versions / Upgrades:

GSM-Messenger A3
- Third alarm input

GSM-Messenger A+
- Power blackout alarm

A Produkt of

TECSON GmbH & Co KG

Wulfsfelder Weg 2a
D-24242 Felde

Tel. (+49) 4340 - 402530
Fax (+49) 4340 - 402529

>> www.tecson.de <<

Basic Functions

The GSM-Messenger is a remote monitoring system for tank filling levels (liter), meter readings and alarm events. The device operates with an integrated GSM mobile phone module that registers itself on the respective mobile network.

The LINK input can be connected to 1-4 TECSON oil level indicators. Additionally the device monitors the two event inputs A1 and A2 which are connected to a potential-free break or make contact (Relays / Reed).

In the event of an alarm or in appointed time intervals the GSM-Messenger automatically reports the current plant status. Therefore the Messenger generates an SMS with a plant identifier (header), report reason, liter inventory, meter readings and plant status. The data is sent to the parameterized destination phone number via SMS. Under normal reception conditions the attached antenna is sufficient for the internal GSM radio module. For bad reception areas an external mobile radio antenna with a 5m to 10m cable can be connected. Such an outdoor antenna is available as an equipment accessory.

The GSM-Messenger indicates the device status via 4 LEDs (see page 6).

After a power or mobile network blackout the device automatically redials into the GSM mobile network.

Counting Functions

Since software version V3.xx the GSM-Messenger contains an integrated counter function.

For device versions V2.xx the special variant Messenger C+, 2+ or A+ was necessary for a counter function.

For these counter functions potential-free switching contacts are connected to input A1 or A2.

These are typically either reed contacts, relay outputs or make/break contacts.

Via inputs A1 and A2 the following counting functions are applicable

- Impulse counter (e.g. water meter with reed output)
- Event counter (counts how often the contact has been closed, i.e. how often an event has occurred)
- Operating hours counter (e.g. time counter that indicates how long a contact state persists)

The counting mode can be activated and parameterized via command #Ai=ö .

See enclosed description **Messages, Commands and Parameters for the GSM-Messenger**%

SIM Card

A prepaid or contract SIM card needs to be inserted into the GSM radio module.

This SIM card has to be operative i.e. it has to be registered and activated.

After entering the PIN code at the device the GSM-Messenger automatically dials up into the respective mobile network. When using a prepaid SIM card the prepaid credit needs to be recharged if empty. This can be done e.g. via internet contractor or at an ATM.

OilView Connection

If the device is connected to the www.oilview.de system all device settings can be performed by the OilView systems administrator/user. Only exception: The PIN entry is to be performed via the device keys.

If the OilView system is not desired the whole parameter settings as well as the device communication is to be made per SMS via a mobile phone. The parameters will be transmitted and permanently saved to the device via SMS commands #... . Accordingly all reports generated by the device will be sent via SMS to the parameterized mobile phone numbers.

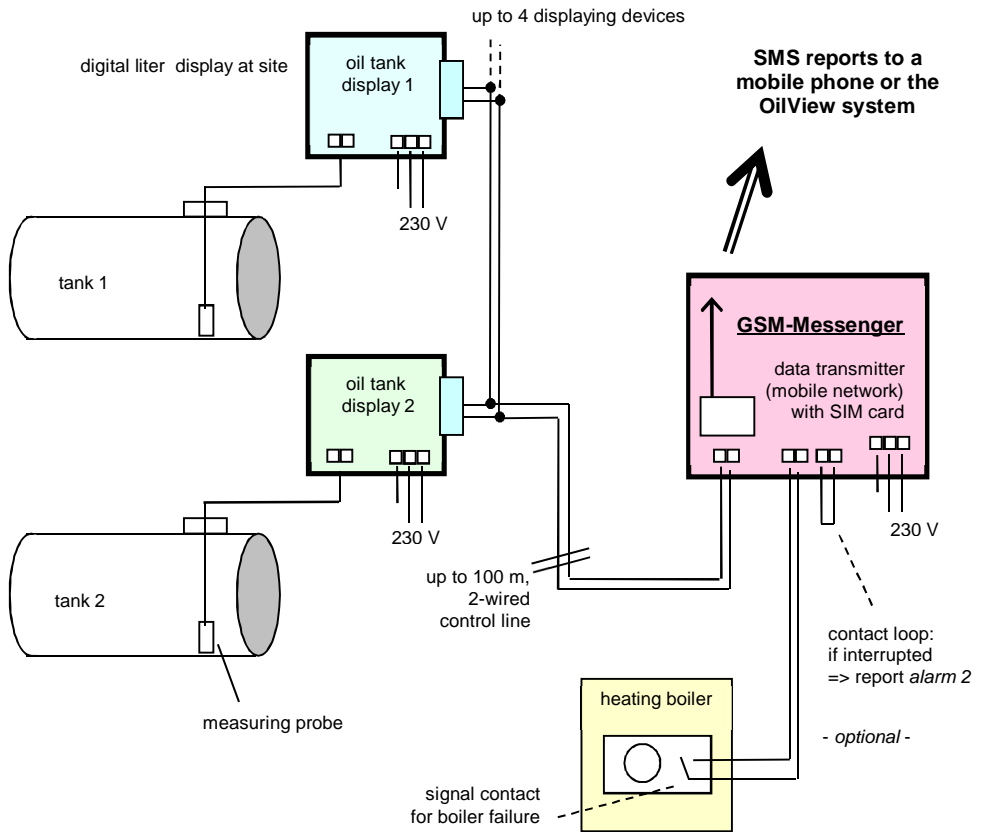

fig.: **Example** of an input wiring:

In the example above two level indicators are connected to the GSM-Messenger.

The alarm input A1 is wired to the boiler failure signal contact. (Potential-free switching contact, possibly interpose a relay.)

Electrical Installation

➤ Recommendation:

Before starting the installation, check the mobile networks signal strength per mobile phone. Normally the reception via the internal GSM-Messenger antenna will be sufficient.

In case of a bad reception location (e.g. a deep basement) potentially mount and install the GSM-Messenger in a higher located room.

In case of a bad reception strength an external mobile antenna might be necessary.

This can for instance be mounted in front of the basement window (equipment accessory, 5m cable)

➤ Mount the device at a spot of the wall that is secure against moisture and insolation.

The device is not suited for an installation in wet rooms or outside.

In such case of operation a protective housing with the respective suitability is necessary.

➤ The connection of a digital tank level indicator (e.g. LX-2, LX-2-R, Smartbox 1/2/3) is to be carried out per signal line (e.g. 2 x 0.4 mm²). Several device outputs are connected in parallel.

➤ The counter and alarm inputs A1 and A2 (resp. A3) are to be connected with potential-free contacts.

Typical are reed contacts in case of counter inputs and relays in case of event inputs.

➤ SIM card:

The SIM card has to be registered and activated.

Before connecting it to the 230V supply voltage, check if the SIM card is inserted and engaged correctly into the designated modem.

➤ Network connection:

Remove the mains fuse, ensure safety (!).

Connect the power supply to the input clamps PE, N, L.

Alternatively a power plug cable can be used for the power socket..

➤ PIN entry:

Activate the power supply and wait for ca. 30 seconds.

When all of the 4 LEDs shine the PIN code has to be entered once.

For the first PIN character press the left button n times, then press OK (right button).

Accordingly repeat the procedure for the other 3 Pin characters

Example PIN:

	3	1	0	2
Inputs:	3 x left button; then OK.	1 x left button; then OK.	0 x left button; then OK.	2x left button; then OK.

8-digit PIN:

If the SIM card has an 8-digit PIN, then the card must be inserted into a smartphone and the PIN code must be deactivated there. Only then insert SIM card into the GSM messenger.

Please note!

➤ The electrical connection and commissioning is only to be carried out by technical qualified personnel.

➤ The device is not suited for an external installation or the operation in wet rooms.

➤ **Attention!** 230V supply voltage is accessible at the power input terminals - mortal danger!

➤ Further electronics are separated from the main voltage, potential-free and conducted in low voltage. After entering the PIN code and potentially triggering the initial report via test button the device cover needs to be closed.

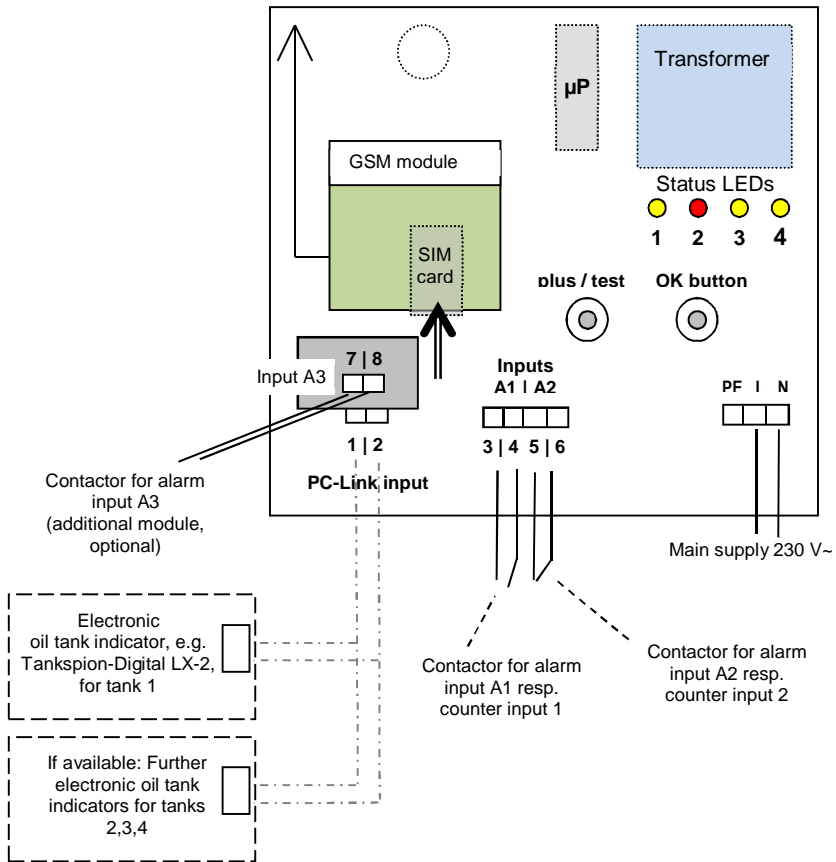

Insertion of the SIM card

A SIM card (prepaid or contract) needs to be inserted into the GSM radio module.

IMPORTANT: The SIM card has to be registered and activated.

After the insertion of the SIM card the device requests to set the PIN code, see page 4.

The sending fees for the SMS reports will be invoiced to the cardholder.

#RESET#:







In case of a device error a software reset possibly solves the error situation. Therefore shortly press both buttons. The adjusted parameters will remain unchanged.

#RESET+Clear#:

The GSM-Messenger software can also be reset into the original delivery status. Therefore press both buttons simultaneously and hold them for 5 sec. During this process all registers and parameters will be reset. Subsequently the **PIN code** of the SIM card needs to be **reentered**. After the modem reconnection the tank reregistration (tank order) possibly needs to be carried out again. The commands #T and #H and all further commands need to be reset via SMS.

Displaying LEDs

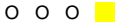
The radiance or flashing of LED 1 (left) to LED 4 (right) has following meanings:

<u>LED meaning</u>		<u>LED's cyclical flashing impulse</u>
LED-1 (yellow) data from indicator.	 1 x	1 flashing impulse (cyclical) => Reception of a filling level telegram from the level indicator.
LED-2 (yellow) sending status activity display	 1x  2x  3x	1 flashing impulse (cyclical) => Network dial-up and registration. <u>Wait for max. 3min!</u> 2 flashing impulses (cyclical) => SMS command is being received. 3 flashing impulses (cyclical) => SMS report is being sent by the GSM-Messenger
LED-3 (RED) <u>GSM Error</u>	 n times undefined blinking red	Error code GSM or modem: <u>Red LED flashes n times? This implies an ERROR:</u> 1 x = Internal modem does not respond. 2 x = No SIM card detected inside the modem. 3 x = PIN invalid (PUK entry necessary, therefore insert the SIM card into a mobile phone). 4 x = Credit is empty. 5 x = No / Bad reception (additional antenna?). 6 x = SIM card is not registered / activated. 7 x = Other modem error. Registration was not successful, if necessary try to reset. 8 x = Interlock active! In case of lots of failed network dial-up trials the device will retry the dial-up only once a day. This mode operates for 255 days. By pushing the [Enter] button the device does one logon trial to mobile network again. In case of successfully sending an SMS the interlock is removed. 9 x = No destination mobile number has been set up. #T command has not been sent or OilView connection has not yet been linked. Device is not sending. Probably <u>internal interlock is active!</u> 1. Disconnect the power supply and switch in again. 2. Query device via smartphone: Send #r as SMS to the device and wait for device replying (3 Min.). 3. Trigger 1 SMS sending by pushing the Test button in the device. 4. In error case check the SIM card with a smartphone. Therefore send a SMS to the own mobile number.
LED-4 (yellow) network reception	 n x	Flashes relative to the network reception. 1 (very poor reception) to 5 (very good reception).
All LEDs on	 (permanently on)	PIN entry request for the SIM card. To adjust the first PIN character press the left button n times, then press OK (right). Accordingly repeat the process for the next 3 characters. <u>With an 8-digit PIN</u> , this must be deactivated with a mobile phone!
Short flashing of all 4 LEDs	 (short flashing)	Due to a problem with the modem communication the GSM-Messenger performs an internal RESET and subsequently tries to redial into the mobile network.

Device Reports

SMS report text (2. Segment of the SMS)	Report reason
Manual query	Manual plant query via SMS command #R or #M.
Info	Cyclical report after n days. n is configurable.
Alarm 1	Alarm signal at input A1, report text: <i>Burner fault</i> (configurable). If the contact closes (configurable) an alarm report will be sent after 4 min.
Alarm 2	Alarm signal at input A1, report text: <i>Contact loop</i> (configurable). If the contact opens (configurable) an alarm report will be sent after 4 min.
Alarm 3	For device type A3 : Alarm signal at input A3. The report text is freely configurable (15 characters). If the contact closes (configurable) <i>alarm 3</i> will be reported after 4 min. For device type A+ : For this device type the alarm input 3 is reconstructed to a blackout alarm function per internal voltage buffer.
Limit at tank 2	Limit level report tank n (n = 1...4).
Tank filling at tank 4	Performed tank filling at tank n. About 1h after the beginning of the tank filling the new inventories will be reported. If connected to the OilView-system the device will also report the low-levels at the beginning of a tank filling (report text: <i>Info tank n</i>). Also via #P7=1.
Check Credit	The credit of the SIM card has fallen below 1". Please recharge the credit!
Parameter Alarm parameter	Configuration query via SMS command #C. Alarm parameter readout via SMS command #A.

Device Parameterization

(A) Parameter setting via OilView

In case of a connection to www.oilview.de the following manual parameterization per SMS commands from the mobile phone is not necessary. The device parameters are comfortably set at the browser pages and transferred from there to the device.

(B) Parameter setting per SMS commands via mobile phone

The parameters are sent as an SMS text from the mobile phone to the device.
Likewise the device also reports to the parameterized phone numbers via SMS.
See enclosed documentation **Messages, Commands and Parameters for GSM-Messenger+**.
The standard commands for status inquiry per mobile phone are #R or #M.

SMS Reports

(A) For OilView

If connected to www.oilview.de the OilView system receives the SMS reports and saves its data.
OilView also displays the plant status (liter, alarm, etc.) graphically.

(B) For mobile phones

See enclosed documentation **Messages, Commands and Parameters for GSM-Messenger+**.

Technical Data

Supply voltage:	230 V AC 50 Hz	
Power consumption:	< 1.2 VA Temporarily higher during sending process.	
Inputs:	Serial link input, cl. 1-2 A1, cl. 3-4 A2, cl. 5-6 A3 optional, see below	Up to 4 level indicators are connectable from series LX-2 or other compatible devices. - Configurable contact input for alarm or counter (potential-free!) - Configurable contact input for alarm or counter (potential-free!) - See device options
Dimensions: H x W X L	120 x 120 x 50 mm	Housing: Polystyrol with Safety class IP30 after EN 60529
Temperature range:	-10 °C to + 45 °C.	The device is to be mounted in the absence of strong solar radiation and humidity.
GSM radio modem:	GPRS Quad band	4G / 2G Radio modem with SIM card purely for SMS communication to be inserted.

Options and Accessory

Order no.		
12068	Option A3 : 3. alarm input (add-on module IF-03)	Option third alarm input A3: This device GSM-Messenger A3 is equipped with an additional input module. A make/break contact is connected to the input clamps. Make contact <u>potential-free!</u>
12269	Option A+ : blackout alarm (add-on module IF-05)	Option A+ : Automatic blackout detection and alerting via SMS.
12069	External antenna with 5m HF-line	For improved reception if the device is e.g. mounted in a basement and the antenna can be mounted outside above-ground, e.g. at the house wall.
12095	www.oilview.de Connection to the data base server	Tank inventory management system. Please inquire at TECSON.

Labeling

	<p>The manufacturer TECSON declares the compliance with the valid safety and test guidelines (CE Declaration).</p> <p>For Conformity Declaration refer to web-site www.tecson.de at menu item Documentationq</p>
---	---

Manufacturer:	TECSON-GmbH & Co KG Wulfsfelder Weg 2a D-24242 Felde	Tel. (+49) 4340 / 402530 Fax (+49) 4340 / 402529 www.tecson.de WEEE No.: DE 18639642
----------------------	---	--