

---

## Devices with Network Connection: LX-NET, LX-Q-NET, e-litro net

---



<u>Content:</u>	<u>Page:</u>
1. Device Types	S. 1
2. Installation and Mounting	S. 2
3. Network Connection	S. 2
4. Network Parameter / Menu 15	S. 4
5. Intranet Access / LAN	S. 6
6. External Access via Internet	S. 8
7.1 Device Communication Test	S. 9
7.2 XML tag, XML Protocol	S. 9
8. E-Mail Sending Function (w.V7.0)	S.10

---

### 1. Device Types:

Available tank monitoring devices with network connection:

#### - Tank-Spion Digital LX-NET or e-litro net

- Tank monitoring device with network connection (RJ45 Ethernet jack 10/100 MBit)
- 1 submersible probe resp. LITRO-Sensor connectable
- 3 additional monitoring devices connectable to display and telecommunication
- 1 alarm contact input
- 1 output relay
- 1 slot for a temperature measuring adaptor or an analog output

#### - Tank-Spion Digital LX-Q-NET

- Tank monitoring device with network connection (RJ45 Ethernet Jack 10/100 MBit)
- up to 4 measuring probes directly connectable
- 1 alarm contact input
- 1 slot for a temperature measuring adaptor
- **E-mail sending function.** New function with V7.0, refer section 8.

## 2. Installation and Mounting

The installation has to be performed according to the device documentation. The device parameters for tank capacity measurement have to be set up as usual following the device documentation.

The displaying devices have a RJ45 jack on the left-hand side for network cable connection (Ethernet). The network communication is configurable under menu item  $\text{q}5.NET\text{q}$

By default DHCP is activated with  $\text{Y}$  (Yes). In this case the device receives its IP address, *subnet mask*, gateway address and DNS server address automatically from the router.

Alternatively the address parameters may be configured manually. Therefore choose  $\text{N}$  (No) at the DHCP setup. Notably the network administrator needs to confirm the port number for the device.

After connecting the network cable the device can be addressed via browser. Therefore the IP address has to be put in the address line of the browser, e.g. 192.168.0.112.

**For these settings it is generally recommended to consult the network administrator.**

## 3. Network Connection

The Ethernet connection is made in the following way:

### 3.1 Direct Connection for the Test

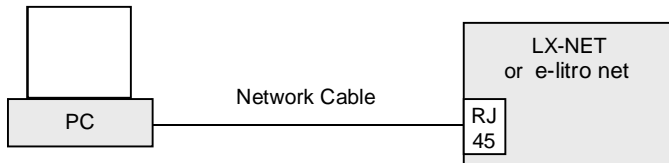

Connect PC/laptop via network cable (cross-over) directly with the devices jack.

### 3.2 Mini Network

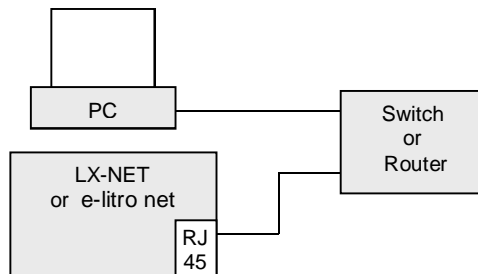

Connect PC/laptop via switch or router with the devices jack.

### 3.3 LAN / Intranet

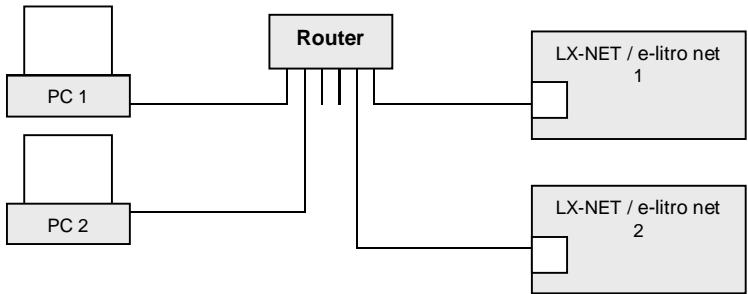

PC and displaying device are directly connected to a local network (LAN / intranet). The displaying device and the PC are required to be in the same network segment or be able to address each other via router.

### 3.4 Internet Access

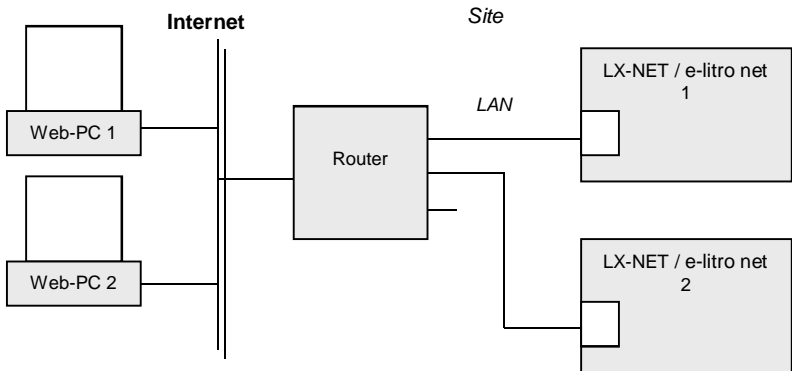

The PC and the monitoring device are connected to the local network resp. to the network router. The devices are accessible from external PCs via internet line and via port forwarding in the router. Additional parameter setup has to be done via browser access to the device at the [Config](#) page.

The first displaying device gets addressed via internet at port 3000. The forwarding of port 3000 to the local IP address has to be setup in the network router. The second displaying device (same local network) gets addressed at port 3001, etc.

Additionally or alternatively the tank monitoring devices can be requested via internet browser. Therefore the site needs a fixed IP address or an established DynDNS service.

## 4. Network Parameter / Menu item **15.Network**

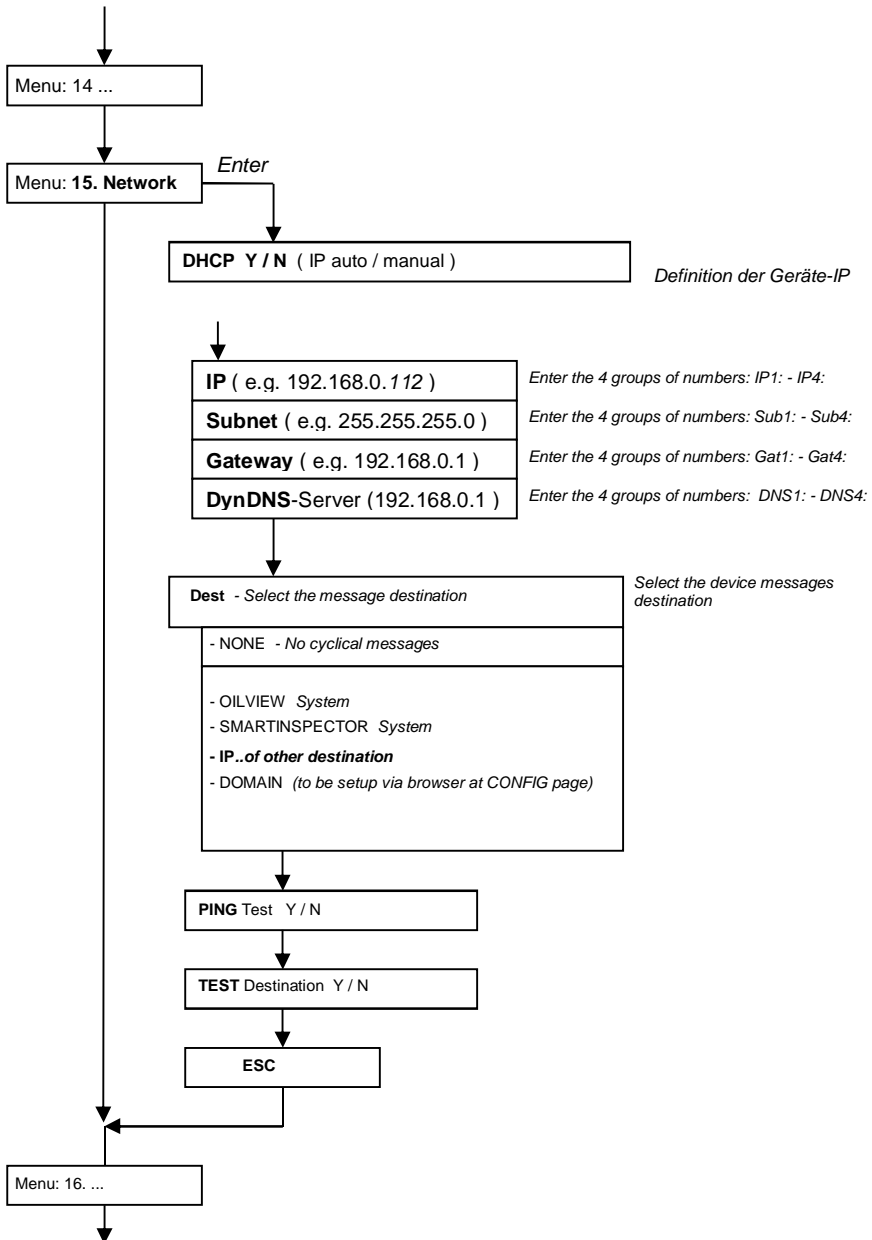

## Router Configuration:

Example: Port forwarding

**Router / Portfreigaben**

http://192.168.0.1/

Startmenü Einstellungen

**Freigaben**

Portfreigaben Fernwartung Dynamic DNS VPN

Liste der Portfreigaben

Aktiv	Bezeichnung	Protokoll	Port	an IP-Adresse	an Port		
<input checked="" type="checkbox"/>	NetBox 1	TCP	3000	192.168.0.112	80		
<input checked="" type="checkbox"/>	NetBox 2	TCP	3001	192.168.0.113	80		

Neue Portfreigabe

Übernehmen Abbrechen Aktualisieren Hilfe

Example: Install DynDNS for a device site

**Router / DynDNS**

http://192.168.0.1/

Startmenü Einstellungen

**Freigaben**

Portfreigaben Fernwartung **Dynamic DNS** VPN

Über Dynamic DNS können Anwendungen und Dienste, für die in der Firewall Portfreigaben eingerichtet wurden, unter einem festen Domainnamen aus dem Internet erreicht werden, obwohl sich die öffentliche IP-Adresse des Routers mit jeder Internetwahl ändert.

Dynamic DNS benutzen

Geben Sie die Anmeldedaten für Ihren Dynamic DNS-Anbieter an.

Dynamic DNS-Anbieter

Domainname

Benutzername

Kennwort

Kennwortbestätigung

Übernehmen Abbrechen Hilfe

## 5. Intranet Access / LAN

The device request in the intranet is made via browser.  
Alternatively the PC application PC-LINK NET can be utilized.

For the request via browser the IP address of the displaying device has to be entered in the address line. If multiple devices are connected in the same intranet they will all have different IPs. It is recommended to either set a bookmark or a desktop link to recall the address.



The screenshot shows a web interface for a device named 'GOK / TECSON'. It includes a 'Config' button in the top right corner. Below the title, there are three lines of information: 'Betreiber: Testfirma Kopenhagen', 'Standort: Kopenhagen Hafen, Geb. 12 - A', and 'Geräte ID: 1234'. A table follows, listing four tanks with their respective contents, percentages, and capacities. The table has columns for Tank-Nr., Bezeichnung, Bestand, in %, Tankgröße, Freiraum, and Temperatur. The 'Total' row shows a combined volume of 54.200 L and 65% fullness. At the bottom, the alarm status is 'Ok - keine Störung'.

Tank-Nr.	Bezeichnung	Bestand	in %	Tankgröße	Freiraum	Temperatur
Tank 1:	Heizöl	14.750 L	85 %	17.350 L	1.735 L	
Tank 2:	Wasser	950 L	9 %	10.500 L	9.025 L	21 °C
Tank 3:	Motoröl	12.000 L	80 %	15.000 L	2.250 L	
Tank 4:	Bio-Diesel	26.500 L	53 %	50.000 L	21.000 L	
Total:		54.200 L	65 %	92.850 L	34.010 L	

Alarmstatus: **Ok** - keine Störung

Fig.: Status page

The browser shows the status of a device, including liter values and system status.

**Config. page:** In addition the configuration page can be called up here via  button.

With maintenance access (password) the device and report parameters can be set at this configuration page.

**Password:** The preset password for the configuration page is: **tank**

We recommend changing the preset password to an individual one.  
The new password can be set at the configuration page.

The standard password **demo** allows a read only access without the rights for changes.

## GOK / Tecson

Betreiber:

Standort:

Geräte ID: 2-14 V3.42

Neues Passwort:

### Tanks

	Bezeichnung	Befüllgrenze	Temperaturgrenzwert
Tank 1:	<input type="text" value="Wasser"/>	95 % <input type="button" value="v"/>	<input type="text"/> °C
Tank 2:	<input type="text" value="Heizöl"/>	95 % <input type="button" value="v"/>	
Tank 3:	<input type="text" value="Heizöl"/>	95 % <input type="button" value="v"/>	
Tank 4:	<input type="text" value="Heizöl"/>	95 % <input type="button" value="v"/>	

### Alarmeidgang

### Relaisausgang

Aktiv  
Ein  
Aus

Fernschaltfunktion für das Relais im LX-NET Gerät:  
- Aktiv = Relais schaltet selbsttätig, abh. von Tankinhalt.  
- Ein = Relais wird hierdurch ferngeschaltet auf EIN.  
- Aus = Relais wird hierdurch ferngeschaltet auf AUS.

### Meldeparameter

Meldeziel:

Kritischer Grenzwert: 15 %

Fig.:  
Configuration page

## Remote Control:

The devices LX-NET / e-litro net resp. LX-GSM / e-litro gsm are equipped with a remote control. Following the operation procedure above the relay output can be set to **on** or **off** by remote control. **Active** means the relay switches automatically, depending on the latest measured value. **Deactive** means the relay remains in passive state (currentless) and its status cannot be requested by remote control.

## 6. External Access via Internet

For a device request via internet the network administrator needs to also configure the network router. There are three different solutions for internet request:

- Request via browser
- Request via PC-LINK NET (Windows application)
- Internet connection to [www.oilview.de](http://www.oilview.de) (or an own system server)

In the intranet (LAN) the devices are addressed via browser (HTML / Port 80). From the internet a device gets addressed via browser by the site IP. If multiple displaying devices are connected at the same site the access is ensued by the site IP + port number of the device.

- LX-NET no.1 <= Site IP : Port 3000.
- LX-NET no.2 <= Site IP : Port 3001.

The port numbers 3000, 3001 resp. 300n are fixed.

### 6.1 Internet Request via Browser:

Only recommended if one of the following conditions is met:

- A: Site has a fixed IP address. Call-up in browser: e.g. <http://84.141.255.229:3000>
- B: A DynDNS service has been set up for the device site.  
Call-up in browser: e.g. <http://myname.dynalias.com:3000>

### 6.2 Internet Request via PC-LINK

PC-Link was a logbook program. This program has been discontinued and will no longer be in the portfolio from 2019.

### 6.3 Internet Connection to an External System ( usually [www.oilview.de](http://www.oilview.de) )

Using this convenient solution the devices are permanently connected to the external system. The devices will report the inventory data, the limiting state and the alert state (alert / no alert) periodically. The OilView system conducts the graphical data presentation and the alert retransmission (configurable).

For this solution no fixed IP address or DynDNS service is necessary at the device site. It is only necessary to conduct the ports of the router to the device IPs.

If for some reason (e.g. safety) this is not possible, then

- the remote call-up of the configuration page is not possible (the configuration page would only be accessible in the local intranet).
- and measuring values cannot be requested manually via ~~refresh~~(the displayed values might not be up to date because the device sends periodically e.g. every 10 mins).



## 7.1 Device Communication Test in the Network

Open up a browser on a PC (recommended are Mozilla Firefox® or MS Internet Explorer®). Enter the IP address of the device in the address line of the browser, e.g. 192.168.1.112 (LAN). The browser will show the status page for the dedicated device (see step 5). To refresh the page press **Strg + F5**

Open up the configuration page by pressing the CONFIG button (see step 5).

For an external request-test the IP address of the site plus (:) and the port number of the device have to be entered, e.g. 95.123.63.15:3000.

### PING Test / SEND Test

The PING test is accessible via menu item **5.Netq=> Test => PING Y/N**. In case of an **OK** response the network communication of the device is functioning.

A communication test to an external system (e.g. OilView) is accessible via menu item **5.Netq=> Test => SEND Y/N**. In case of an **OK** response the network connection, the router configuration and internet connection to the external system are functioning.

## 7.2 Device query using XML protocol or GET method

The device can reply or deliver its current display data in the XML protocol.

The device can be addressed via its IP address with the argument /XML

Query example for browser addressing line: `http://217.70.193.54/XML`

Via program interface the device can be addressed using the GET method. It replies with a XML tag.

## 8. Device or Content Messages via E-mail

with version 7.0:

### 8.1 Configuration of email function and messaging

With the integrated e-mail function, the network device automatically and regularly reports its status (measured values and system status), as well as events (e.g. reserve) to the configured email destination mailbox.

These messages occur in intervals (for example, every 3 days) or whenever the stock changes by x% or when a reportable event occurs.

The parameters are set in the  $\text{CONFIG}$ mask.

This device mask is accessible via browser.

(Enter the IP address of the device in the address bar.)

#### Configuration of email service:

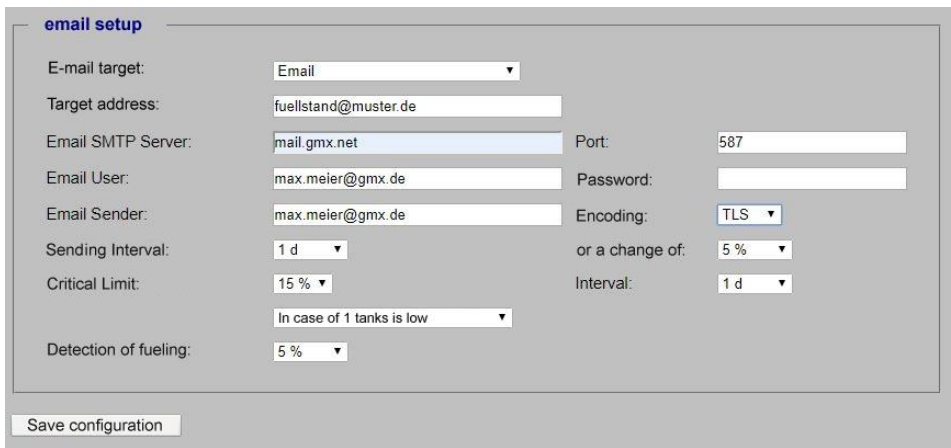

The screenshot shows a web-based configuration interface for email services. The title is "email setup". The form includes the following fields and options:

- E-mail target: Email (dropdown)
- Target address: fuelstand@muster.de (text input)
- Email SMTP Server: mail.gmx.net (text input)
- Port: 587 (text input)
- Email User: max.meier@gmx.de (text input)
- Password: (text input)
- Email Sender: max.meier@gmx.de (text input)
- Encoding: TLS (dropdown)
- Sending Interval: 1 d (dropdown)
- or a change of: 5 % (dropdown)
- Critical Limit: 15 % (dropdown)
- Interval: 1 d (dropdown)
- Detection of fueling: 5 % (dropdown)
- Event description: In case of 1 tanks is low (dropdown)

At the bottom left, there is a "Save configuration" button.

Explanation of the parameters see next page:

## Parameters for email sending service:

Parameter	Description	Example / Presetting
Email target (max. 40 chars)	Receiver, operator, headquarter. The device sends its current messages to this e-mail address.	recipient-name@example.de
Email SMTP server (max. 20 chars)	The SMTP server is the e-mail sending service. The message will be send to the e-mail target: mail.yourdomain.com	Connection security: For secure transmission use SSL encryption, e.g. mail.gmx.net port: 587
Email user (max. 25 chars)	Usually your username is the email address, without specifying the domain. In some cases the email is to be specified with domain.	e.g. max.meier or z.B. max.meiser@gmx.com. (if necessary ask the service provider)
Email sender (max. 25 chars)	Your e-mail address.	e.g. max.meier@gmx.de
Sending interval	Message interval in days or hours or % change: e.g. 1d means report after 1 day. as well as % of inventory change (since last message)	e.g. 5d (range 1d ... 15d). Even hours are possible for example. 1h, 4h, 12h or disabled.  Or at xx% of change.
Critical limit	Reporting threshold in %. When reached a message will be send.  Additionally choose ☒ falling below or ☒ exceeding limit	e.g. 15% (range 0% ... 99%)  Time interval for repeating: 1 ... 15d or 1h, 4h, 12h or deactivated Select between withdrawal tank(s) and collection tank(s).
Detection of fueling	% value of inventory change for refueling detection and event notification.	e.g. 5% Range is 1% ... 20% or deactivated

## 8.2 Testing the e-mail messaging

The **Save configuration** button saves the settings in the device. A communication test is carried out as soon as the configuration page is left. The device shows the transmission process.

If the device reports an OK, then the e-mail function is set up properly. If the parameters are not correct or if the device cannot establish a connection then transmit status **Error** will be displayed.

<b>Operator:</b>	Tom McEmail			
<b>Location:</b>	Berlin			
<b>Device:</b>	LX-Net			
<b>Send status:</b>	...			
<b>Tank</b>	<b>Content</b>	<b>in %</b>	<b>Volume</b>	<b>Clearance</b>
Tank 1: Heating oil	4.705 L	68 %	6.900 L	1.850 L

Fig. 1: Transmission attempt (when closing the configuration setup window).

<b>Operator:</b>	Tom McEmail			
<b>Location:</b>	Berlin			
<b>Device:</b>	LX-Net			
<b>Send status:</b>	Ok			
<b>Tank</b>	<b>Content</b>	<b>in %</b>	<b>Volume</b>	<b>Clearance</b>
Tank 1: Heating oil	4.705 L	68 %	6.900 L	1.850 L

Fig.2: Sending test was successful.

<b>Operator:</b>	Tom McEmail			
<b>Location:</b>	Berlin			
<b>Device:</b>	LX-Net			
<b>Send status:</b>	Error (Fehler)			
<b>Tank</b>	<b>Content</b>	<b>in %</b>	<b>Volume</b>	<b>Clearance</b>
Tank 1: Heating oil	4.705 L	68 %	6.900 L	1.850 L

Fig. 3: Sending attempt has failed.